

Manual Hand Pallet Truck

20HP/25HP/30HP

Standard Configurations

- Polyurethane drive steering wheel
- Double Polyurethane Fork wheels
- Overall Fork Width x Length : 550mm x 1,150mm
- Rubber Wrapped handgrip (25HP)

Option

- Nylon drive wheel and double nylon fork wheel
- Rubber drive wheel and double Polyurethane Fork wheel
- Polyurethane drive wheel and single Polyurethane Fork wheel (20HP/25HP)
- Nylon drive wheel and single nylon Fork wheel (20HP/25HP)
- Extra long foot pedal release (25HP/30HP)
- Quick lift (5 strokes to reach max.height) (25HP)
- Fork length (mm) 800, 900, 1000, 1100
- Overall Fork width x Length : 685mm x 1,220mm

photo may include optional equipment.

Dimension & Specifications (according to VDI 2198)

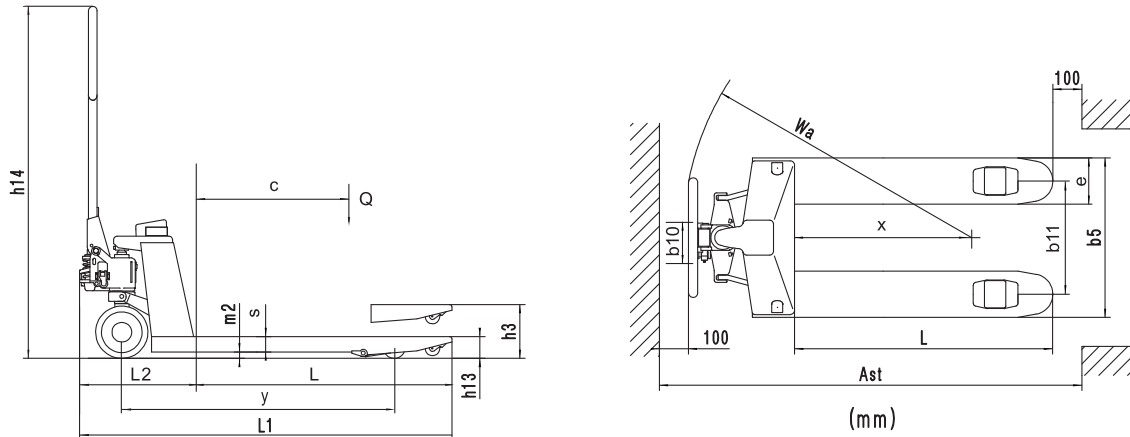

| Characteristics | | | | | | |
|-----------------|--|-------|--------------|--------------|--------------|-------------|
| 1.1 | Manufacturer(abbreviation) | | Hyundai | Hyundai | Hyundai | |
| 1.2 | Model | | 20HP | 25HP | 30HP | |
| 1.3 | Drive type | | manual | manual | manual | |
| 1.4 | Operator type | | hand | hand | hand | |
| 1.5 | Load capacity/rated load | kg | 2000 | 2500 | 3000 | |
| 1.6 | Load center distance | c | mm | 22 | 32 | 40 |
| 1.8 | Load distance | x | mm | 600 | 600 | 600 |
| 1.9 | Wheelbase | y | mm | 1136 | 1153 | 1124 |
| Weight | | | | | | |
| 2.1 | Service weight | kg | 55 | 58 | 63 | |
| Wheels/Chassis | | | | | | |
| 3.1 | Tyres: solid rubber, superelastic, pneumatic, polyurethane | | polyurethane | polyurethane | polyurethane | |
| 3.2 | Tyre size, front(Steering wheel) | mm | Φ 160 | Φ 200 | Φ 200 | |
| 3.3 | Tyre size, rear(Fork wheel single) | mm | Φ 70x80 | Φ 80x93 | - | |
| | Tyre size, rear(Fork wheel tandem) | mm | Φ 70x60 | Φ 80x70 | Φ 80x70 | |
| 3.5 | Wheels number, front/rear (x = driven wheels) | | 2x+2/4 | 2x+2/4 | 2x+2/4 | |
| 3.6 | Tread, front | b10 | mm | 108 | 111 | 120 |
| 3.7 | Tread, rear | b11 | mm | 400/535 | 390/525 | 390/525 |
| Dimension | | | | | | |
| 4.4 | Max. Lift height | h3 | mm | 190 | 195 | 200 |
| 4.9 | Min. /Max. height of operation handle, in driving position | h14 | mm | 1176.5 | 1224 | 1224 |
| 4.15 | Height, lowered | h13 | mm | 75 | 85 | 85 |
| 4.19 | Overall length | l1 | mm | 1520 | 1543 | 1533 |
| 4.20 | Length to fork face | l2 | mm | 370 | 393.5 | 384 |
| 4.22 | Fork dimension | s/e/l | mm | 53/150/1150 | 53/160/1150 | 45/160/1150 |
| 4.25 | Overall width of fork | b5 | mm | 550/685 | 550/685 | 550/685 |
| 4.32 | Wheelbase ground distance | m2 | mm | 22 | 32 | 32 |
| 4.33 | Aisle width, with pallet 1000x1200 crosswise | Ast | mm | 1720 | 1743 | 1733 |
| 4.34 | Aisle width, with pallet 800x1200 lengthwise | Ast | mm | 1770 | 1793 | 1783 |
| 4.35 | Turning radius | Wa | mm | 1265 | 1276 | 1266 |