

Hyundai Warehouse Equipment

Electric Pallet truck, Electric Stacker and Manual Hand Pallet Truck

MOVING YOU FURTHER

HYUNDAI HEAVY INDUSTRIES



■ Photo may include optional equipment.

 **HYUNDAI**

Electric Pallet truck

15/18/20EP



■ Photo may include optional equipment.

Standard Configurations

15EP

- Lifting Capacity : 1500 kg
- Brushless Drive Motor : 0.9 kW
- Lifting Motor : 0.8 kW
- Drive Wheel : 195 x 70 mm
- Double Polyurethane Load wheel (size: 80 x 70 mm)
- Hourmeter, Battery Discharge Indicator (BDI) & lift cut off
- Overall Fork Width x Length : 550 mm x 1150 mm
- Turtle switch / crawl speed button
- Belly switch
- Gel battery
- Integrated charger
- Emergency switch
- Ergonomic tiller

18EP

- Lifting Capacity : 1800 kg
- AC Drive Motor : 1.2 kW
- Lift motor : 1.2 kW
- Curtis controller
- Drive wheel : 250 x 70 mm
- Double Polyurethane Load wheel (size: 80 x 70 mm)
- Hourmeter, Battery Discharge Indicator (BDI) & lift cut off
- Overall Fork Width x Length : 550 mm x 1150 mm
- Turtle switch / crawl speed button
- Ergonomic low-mounted tiller
- Side Battery Removal
- Emergency switch
- Belly switch

20EP

- Lifting Capacity : 2000 kg
- AC Drive Motor : 1.2 kW
- Lift motor : 1.2 kW
- Curtis controller
- Drive wheel : 250 x 70 mm
- Double Polyurethane Load wheel (size: 82 x 98 mm)
- Hourmeter, Battery Discharge Indicator (BDI) & lift cut off
- Overall Fork Width x Length : 550 mm x 1150 mm
- Turtle switch / crawl speed button
- Ergonomic low-mounted tiller
- Side Battery Removal
- Emergency switch
- Belly switch

Advantages

SAFETY AND PRODUCTIVITY

- AC technology gives high performance and low maintenance (no carbon brushes)
- Intelligent regenerative brake system for fast and efficient handling
- Side battery removal, for multiple shift operation
- Turtle mode switch, for safe maneuverability with tiller in upright position
- Proportional speed control ensures precise operation
- Anti roll-back on gradients (parking brake)

STRUCTURE DESIGN

- The motor structure is resistant to dust and moisture
- Improved lateral stability thanks to spring applied castor wheels
- Torsion resistant forks, welded type

SERVICEABILITY

- Increased serviceability by CANbus technology
- Grease fittings on all pivot points increase durability
- Easy access to all components thanks to removal of only 1-piece front cover

Dimensions

15EP

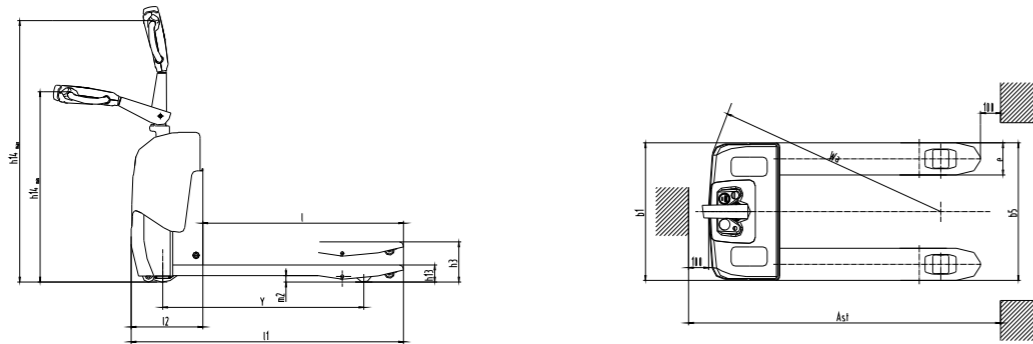

18/20EP

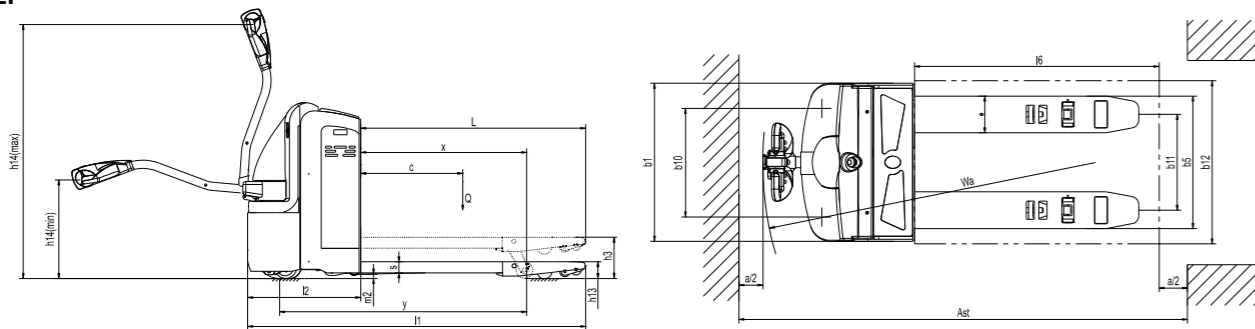

Option

15EP

- Loadguard 1220 mm
- Fork length (mm): 900; 1000; 1220
- Single PU Load Wheel (size: 80 x 93 mm)

18EP

- Integrated Charger (24V / 15A)
- Battery trolley
- Foot protection strip
- Keyless ignition (keypad)
- Loadguard 1220 mm
- Fork length (mm): 800; 900; 1000; 1220; 1600; 1800; 2400 mm (1800; 2400 : rated load capacity 1.5t)

20EP

- Integrated Charger (24V / 15A)
- Battery trolley
- Foot protection strip
- Keyless ignition (keypad)
- Loadguard 1220 mm
- Fork length (mm): 800; 900; 1000; 1220; 1600; 1800; 2400 mm (1800; 2400 : rated load capacity 1.5t)
- Single PU load wheel (size: 82 x 98 mm)

Specification (according to VDI 2198)

Characteristics						
1.1	manufacturer (abbreviation)		Hyundai	Hyundai	Hyundai	
1.2	Model		15EP	18EP	20EP	
1.3	Drive type		electric	electric	electric	
1.4	Operator type		pedestrian	pedestrian	pedestrian	
1.5	Load capacity/rated load	Q	kg	1500	1800	2000
1.6	Load center distance	c	mm	600	600	600
1.8	Load distance	x	mm	886 / 956	856	815 / 865 / 935
1.9	Wheelbase	y	mm	1152 / 1222	1200	1211 / 1261 / 1331
Weight						
2.1	Service weight (with battery)		kg	240	535	640
2.2	Axle load, front/rear, loaded		kg	442 / 1288	720 / 1600	1170 / 1450
2.3	Axle load, front/rear, unloaded		kg	200 / 30	420 / 100	470 / 150
Wheels/Chassis						
3.1	Tyres: solid rubber, super elastic, pneumatic, polyurethane			polyurethane	polyurethane	polyurethane
3.2	Tyre size, front			Φ 195 x 70	Φ 250 x 70	Φ 250 x 70
3.3	Tyre size, rear			Φ 80 / Φ 70	Φ 80 x 70	Φ 82 x 126
3.4	Additional wheels (dimensions)			Φ 60 x 35	Φ 114 x 60	Φ 127 x 57
3.5	Wheels number, front/rear (x = driven wheels)			1x -2/4	1x +2/4	1x +2/2
3.6	Tread, front	b10	mm	195	476	510
3.7	Tread, rear	b11	mm	80 / 74	400	340 / 370 / 470 / 505
Dimension						
4.4	Lift height	h5	mm	105 / 115	120	120
4.9	Min. / Max. height of operation handle, in driving position	h14	mm	950 / 1310	780 / 1230	780 / 1230
4.15	Height, lowered	h13	mm	85 / 75	84	82
4.19	Overall length	l1	mm	1525 / 1595	1651	1655 / 1705 / 1775
4.20	Length to fork face	l2	mm	375	500	555
4.21	Overall width of truck body	b1	mm	685	682	775
4.22	Fork dimension	s/e/l	mm	53 x 160 x 1150	54 x 150 x 1150	54 x 180 x 1150
4.25	Overall width of fork	b5	mm	520 / 550 / 685	550	520 / 550 / 650 / 685
4.32	Wheelbase ground distance	m2	mm	32 / 22	28	28
4.33	Aisle width, with pallet 1000 x 1200 crosswise	Ast	mm	1725 / 1795	1863	2015 / 2065 / 2135
4.34	Aisle width, with pallet 800 x 1200 lengthwise	Ast	mm	1775 / 1795	1913	2115 / 2115 / 2135
4.35	Turning radius	Wa	mm	1347 / 1415	1367	1400 / 1450 / 1520
Performance Data						
5.1	traveling speed, loaded/unloaded		km/h	5.8 / 6.0	5.8 / 6.0	5.8 / 6.0
5.2	Lifting speed, loaded/unloaded		m/s	0.035 / 0.045	0.06 / 0.11	0.039 / 0.056
5.3	Lowering speed, loaded/unloaded		m/s	0.08 / 0.037	0.12 / 0.13	0.064 / 0.050
5.7	Gradeability, loaded/unloaded		%	5 / 15	8 / 20	6 / 12
5.10	traveling brake			electromagnetic brake	electromagnetic brake	electromagnetic brake
Motor						
6.1	Driving motor power		kW	0.9	1.2	1.2
6.2	Lifting motor power		kW	0.8	1.2	1.2
6.4	Battery voltage/rated capacity		V/Ah	24 / 80	24 / 160	24 / 210
6.5	Battery weight		kg	49	160	170

Electric Pallet truck

20/25EPR



■ Photo may include optional equipment.

Standard Configurations

20EPR

- Lifting Capacity : 2000 kg
- AC Drive Motor : 1.5 kW (9 km/h)
- Lift motor : 1.2 kW
- Curtis controller
- Drive wheel : 250 x 70 mm
- Double Polyurethane load wheel (size: 82 x 98 mm)
- Hourmeter, battery discharge indicator (BDI) & lift cut off
- Overall Fork Width x Length : 550 mm x 1150 mm
- Turtle switch / crawl speed button
- Tiller head with big control buttons
- Side Battery Removal
- EPS (Electric Power Steering)
- Stand on platform

25EPR

- Lifting Capacity : 2500 kg
- AC Drive Motor : 1.5 kW (6 km/h)
- Lift motor : 1.2 kW
- Curtis controller
- Drive wheel : 250 x 70 mm
- Double Polyurethane Load wheel (size: 82 x 98 mm)
- Hourmeter, battery discharge indicator (BDI) & lift cut off
- Overall Fork Width x Length : 550 mm x 1150 mm
- Turtle switch / crawl speed button
- Tiller head with big control buttons
- Side Battery Removal
- EPS (Electric Power Steering)
- Stand on platform

Advantages

SAFETY AND PRODUCTIVITY

- AC technology gives high performance and low maintenance (no carbon brushes)
- Intelligent regenerative brake system: increase overall truck performance.
- Side battery removal, for multiple shift operation
- Turtle mode switch, for safe maneuverability with tiller in upright position
- Proportional travel speed control
- Anti roll-back on gradients
- Effortless steering (EPS), less fatigue
- Automatic speed reduction relative to steer angle
- Suspended platform for comfortable operation

STRUCTURE DESIGN

- The closed motor structure is water- and dust resistant (IP 44)
- Spring-loaded castors improve lateral stability on uneven floors and enhance truck performance and service life.
- Welded type fork.

SERVICEABILITY

- CANbus technology reduces wiring complexity.
- All pivot points have grease fittings and serviceable bushings, to reduce component-wearing.
- Easy access to all components thanks to removal of 1-piece front cover.

Dimensions

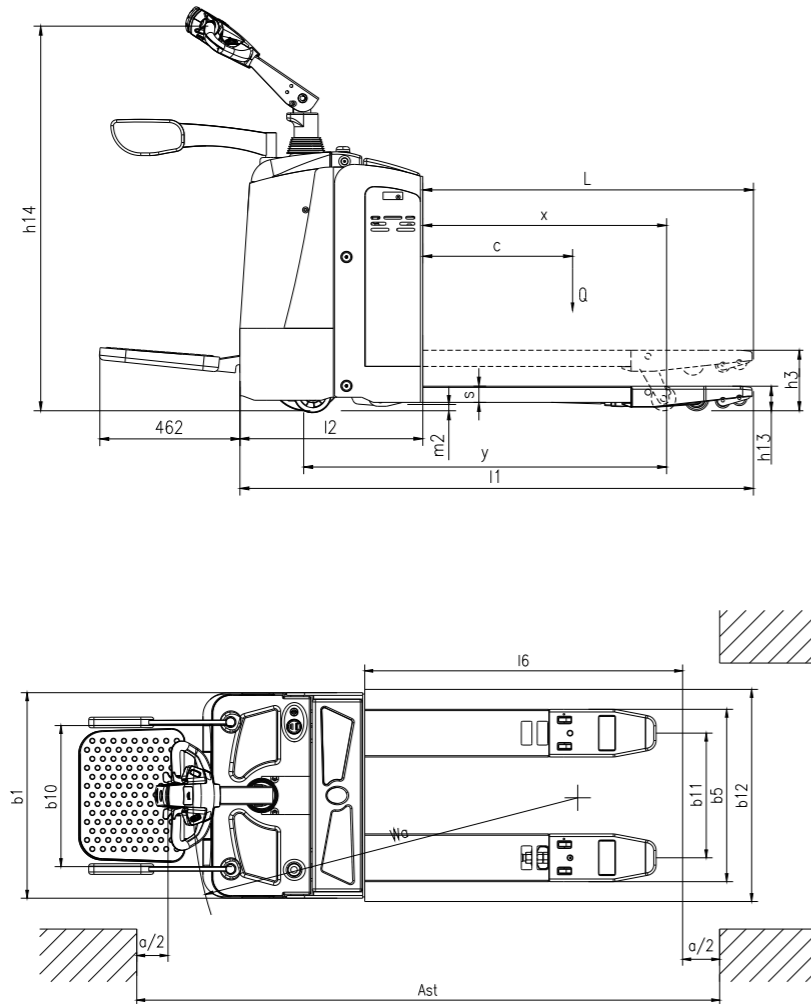

Option

- Traveling speed 6 km/h (1.6 kw Drive motor, Curtis controller 1232)
- Curtis steering controller
- Integrated charger (24V / 20A)
- Coldstore specification -18°C
- Closed operator protection
- Keyless ignition (keypad) (start)
- Loadguard 1220 mm
- Battery trolley
- Fork length (mm)
 - 20EPR : 800; 900; 1000; 1200; 1600; 1800; 2400
 - 25EPR : 800; 900; 1000; 1200; 1600; 1800; 2400 (1800; 2400 : rated load capacity 1.5t)

Specification (according to VDI 2198)

Characteristics			
1.1	manufacturer (abbreviation)		Hyundai / Hyundai
1.2	Model		20EPR / 25EPR
1.3	Drive type		Electric / Electric
1.4	Operator type		pedestrian / standing / pedestrian / standing
1.5	Load capacity/rated load	Q kg	2000 / 2500
1.6	Load center distance	c mm	600 / 600
1.8	Load distance	x mm	818 / 868 / 938 / 818 / 868 / 938
1.9	Wheelbase	y mm	1302 / 1352 / 1422 / 1302 / 1352 / 1422
Weight			
2.1	Service weight (with battery)	kg	720 / 750
2.2	Axle load, front/rear, loaded	kg	1640 / 1030 / 2040 / 1180
2.3	Axle load, front/rear, unloaded	kg	160 / 560 / 160 / 560
Wheels/Chassis			
3.1	Tyres: solid rubber, super elastic, pneumatic, polyurethane		polyurethane / polyurethane
3.2	Tyre size, front		Φ 250 x 80 / Φ 250 x 80
3.3	Tyre size, rear		Φ 80 x 70 / Φ 74 x 70
3.4	Additional wheels (dimensions)		Φ 127 x 57 / Φ 127 x 57
3.5	Wheels number, front/rear (x = driven wheels)		1x +2/4 / 1x +2/4
3.6	Tread, front	b10 mm	491 / 491
3.7	Tread, rear	b11 mm	340 / 370 / 470 / 505 / 340 / 370 / 470 / 505
Dimension			
4.4	Lift height	h5 mm	120 / 120
4.9	Min. / Max. height of operation handle, in driving position	h14 mm	1150 / 1450 / 1150 / 1450
4.15	Height, lowered	h13 mm	75 / 85 / 75 / 85
4.19	Overall length	l1 mm	1710 / 1760 / 1830 / 1710 / 1760 / 1830
4.20	Length to fork face	l2 mm	610 / 610
4.21	Overall width of truck body	b1 mm	775 / 775
4.22	Fork dimension	s/e/l mm	53 x 180 x 1100 (1150 / 1220) / 53 x 180 x 1100 (1150 / 1220)
4.25	Overall width of fork	b5 mm	520 / 550 / 650 / 685 / 520 / 550 / 650 / 685
4.32	Wheelbase ground distance	m2 mm	30 / 30
4.33	Aisle width, with pallet 1000 x 1200 crosswise	Ast mm	1910 / 1960 / 2030 / 1910 / 1960 / 2030
4.34	Aisle width, with pallet 800 x 1200 lengthwise	Ast mm	2010 / 2010 / 2030 / 2010 / 2010 / 2030
4.35	Turning radius	Wa mm	1550 / 1600 / 1670 / 1550 / 1600 / 1670
Performance Data			
5.1	traveling speed, loaded/unloaded	km/h	6.1 / 9.0 / 6.1 / 9.0
5.2	Lifting speed, loaded/unloaded	m/s	0.03 / 0.032 / 0.03 / 0.032
5.3	Lowering speed, loaded/unloaded	m/s	0.032 / 0.03 / 0.032 / 0.03
5.7	Gradeability, loaded/unloaded	%	4 / 8 / 3 / 8
5.8	Max. gradeability, loaded/unloaded		8 / 20 / 6 / 20
5.10	traveling brake		electromagnetic brake / electromagnetic brake
Motor			
6.1	Driving motor power	kW	1.5 / 1.5
6.2	Lifting motor power	kW	1.2 / 1.2
6.4	Battery voltage/rated capacity	V/Ah	24 / 240 / 24 / 240
6.5	Battery weight	kg	240 / 240

Electric pallet truck (Double deck)

20EDPR



■ Photo may include optional equipment.

Standard Configurations

20EDPR

- Lifting Capacity : 1x 2000 kg (2x 1000 kg)
- AC Drive Motor : 1.5 kW
- Lift motor 2.2 kW
- Curtis controller
- Drive wheel : 250 x 70mm
- Double Polyurethane Load wheel (size: 80 x 70 mm)
- Lift height 2500 mm (Triple mast free lift)
- Hourmeter, battery discharge indicator (BDI) with lift cut off
- Overall Fork Width x Length : 570 x 1150 mm
- Tiller head with big proportional controls
- Side Battery Removal
- EPS (Electric Power Steering)
- Maximum travelling speed : 9 km/h
- Stand on platform
- Loadguard

Advantages

SAFETY AND PRODUCTIVITY

- AC technology gives high performance and low maintenance (no carbon brushes)
- Intelligent regenerative brake system: increase overall truck performance.
- Side battery removal, for multiple shift operation
- Turtle mode switch, for safe maneuverability with tiller in upright position
- Proportional travel speed control
- Anti roll-back on gradients
- Effortless steering (EPS), less fatigue
- Automatic speed reduction relative to steer angle
- Suspended platform for comfortable operation
- Precision in handling due to proportional hydraulics

STRUCTURE DESIGN

- The closed motor structure is water- and dust resistant (IP 44)
- Spring-loaded castors improve lateral stability on uneven floors and enhance truck performance and service life.
- Welded type fork.

SERVICEABILITY

- CANbus technology reduces wiring complexity.
- All pivot points have grease fittings and serviceable bushings, to reduce component-wearing.
- Easy access to all components thanks to removal of 1-piece front cover.

Dimensions

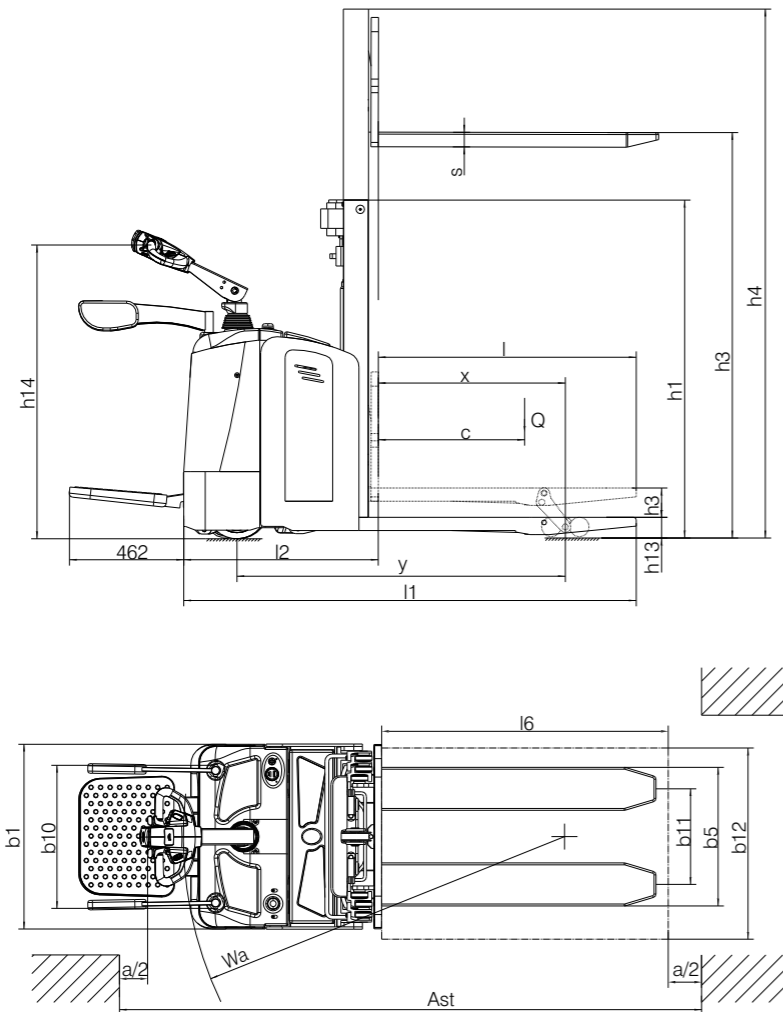

Option

- Coldstore specification -18°C
- Keyless ignition (keypad)
- Battery trolley
- Fork length (mm): 800; 900; 1000; 1220
- Lifting height 1600 mm (Triple mast free lift)
- Lifting height 2000 mm (Triple mast free lift)
- Single PU load wheel

Specification (according to VDI 2198)

Characteristics			
1.1	manufacturer (abbreviation)		Hyundai
1.2	Model		20EDPR
1.3	Drive type		electric
1.4	Operator type		pedestrian / standing
1.5	Load capacity/rated load	Q	kg 2000
1.6	Load center distance	c	mm 600
1.8	Load distance	x	mm 767
1.9	Wheelbase	y	mm 1348
Weight			
2.1	Service weight (with battery)		kg 1130
2.2	Axle load, front/rear, loaded		kg 1090 / 2040
2.3	Axle load, front/rear, unloaded		kg 840 / 290
Wheels/Chassis			
3.1	Tyres: solid rubber, super elastic, pneumatic, polyurethane		polyurethane
3.2	Tyre size, front		Φ 250 × 80
3.3	Tyre size, rear		Φ 80 × 70
3.4	Additional wheels (dimensions)		Φ 127 × 57
3.5	Wheels number, front/rear (x = driven wheels)		1x +2/4
3.6	Tread, front	b10	mm 490
3.7	Tread, rear	b11	mm 400 / 470
Dimension			
4.2	Height of mast, lowered	h1	mm 1082 / 1212 / 1382
4.4	Lift height	h5	mm 1600 / 2000 / 2500
4.5	Max. height of mast, extended	h3	mm 2118 / 2508 / 3018
4.7	Lifting height for leg	h4	mm 120
4.9	Min. / Max. height of operation handle, in driving position	h14	mm 1150 / 1430
4.15	Height, lowered	h13	mm 90
4.19	Overall length	l1	mm 1898 / 1948
4.20	Length to fork face	l2	mm 798
4.21	Overall width of truck body	b1	mm 775
4.22	Fork dimension	s/e/l	mm 54 × 180 × 1150
4.25	Overall width of fork	b5	mm 570 / 650
4.32	Wheelbase ground distance	m2	mm 28
4.33	Aisle width, with pallet 1000 x 1200 crosswise	Ast	mm 2098 / 2148
4.34	Aisle width, with pallet 800 x 1200 lengthwise	Ast	mm 2198
4.35	Turning radius	Wa	mm 1600
Performance Data			
5.1	traveling speed, loaded/unloaded		km/h 6.2 / 9.0
5.2	Lifting speed, loaded/unloaded		m/s 0.11 / 0.19
5.3	Lowering speed, loaded/unloaded		m/s 0.16 / 0.11
5.7	Gradeability, loaded/unloaded		% 6 / 12
5.8	Max. gradeability, loaded/unloaded		8 / 20
5.10	traveling brake		electromagnetic braking
Motor			
6.1	Driving motor power		kW 1.5
6.2	Lifting motor power		kW 2.2
6.4	Battery voltage/rated capacity		V/Ah 24 / 240
6.5	Battery weight		kg 235

Electric Pallet truck

10/12/15ES



■ Photo may include optional equipment.

Standard Configurations

10ES

- Lifting Capacity : 1000 kg
- AC Drive Motor : 1.2 kW / Lift motor 2.2 kW
- Curtis controller
- Drive wheel : 250 x 70 mm
- Double Polyurethane Load wheel (size: 80 x 70 mm)
- Hourmeter, battery discharge indicator (BDI) & lift cut off
- Duplex 3.0 m Mast without free lift
- Overall Fork Width x Length : 580 mm x 1150 mm
- Turtle switch / crawl speed button
- Tiller head with big control buttons
- Automatic Drive speed reduction (lifting over 1.8 m)
- Ergonomic low-mounted tiller
- Loadguard

12ES

- Lifting Capacity : 1200 kg
- AC Drive Motor : 1.2 kW / Lift motor 2.2 kW
- Curtis controller
- Drive wheel : 250 x 70 mm
- Double Polyurethane Load wheel (size: 80 x 70 mm)
- Hourmeter, battery discharge indicator (BDI) & lift cut off
- Duplex 3.0 m Mast without free lift
- Overall Fork Width x Length : 580 mm x 1150 mm
- Turtle switch / crawl speed button
- Tiller head with big control buttons
- Automatic Drive speed reduction (lifting over 1.8 m)
- Ergonomic low-mounted tiller
- Loadguard

15ES

- Lifting Capacity : 1500 kg
- AC Drive Motor : 1.5 kW / Lift motor 3.2 kW
- Curtis controller
- Drive wheel : 250 x 70 mm
- Double Polyurethane Load wheel (size: 84 x 80 mm)
- Hourmeter, battery discharge indicator (BDI) & lift cut off
- Duplex 3.0 m Mast with free lift
- Overall Fork Width x Length : 570 mm x 1150 mm
- Turtle switch / crawl speed button
- Tiller head with big control buttons
- Proportional Lifting
- Automatic Drive speed reduction (lifting over 1.8m)
- Ergonomic low-mounted tiller
- Loadguard

Advantages

SAFETY AND PRODUCTIVITY

- AC technology gives high performance and low maintenance (no carbon brushes)
- Multi-functional display with BDI and hour meter.
- Proportional travel speed control.
- Switch shuts off liftmotor.
- Intelligent regenerative brake system for fast and efficient handling
- Proportional speed control ensures precise operation
- Anti roll-back on gradients (parking brake)
- Precision in storage and retrieval operations due to proportional hydraulics (15ES)
- Side battery removal for multiple shift operations
- Turtle mode switch, for safe maneuverability with tiller in upright position
- Long tiller ensures large safety distance between operator and truck

STRUCTURE DESIGN

- The closed motor structure is water- and dust resistant
- Improved lateral stability thanks to spring applied castor wheels
- Torsion resistant forks, welded type
- Offset low mounted tiller for improved visibility
- Lifting height up to 5000 mm

SERVICEABILITY

- CANbus technology reduces wiring complexity.
- All pivot points have grease fittings and serviceable bushings, to reduce component-wearing.
- Easy access to all components thanks to removal of 1-piece front cover.

Dimensions

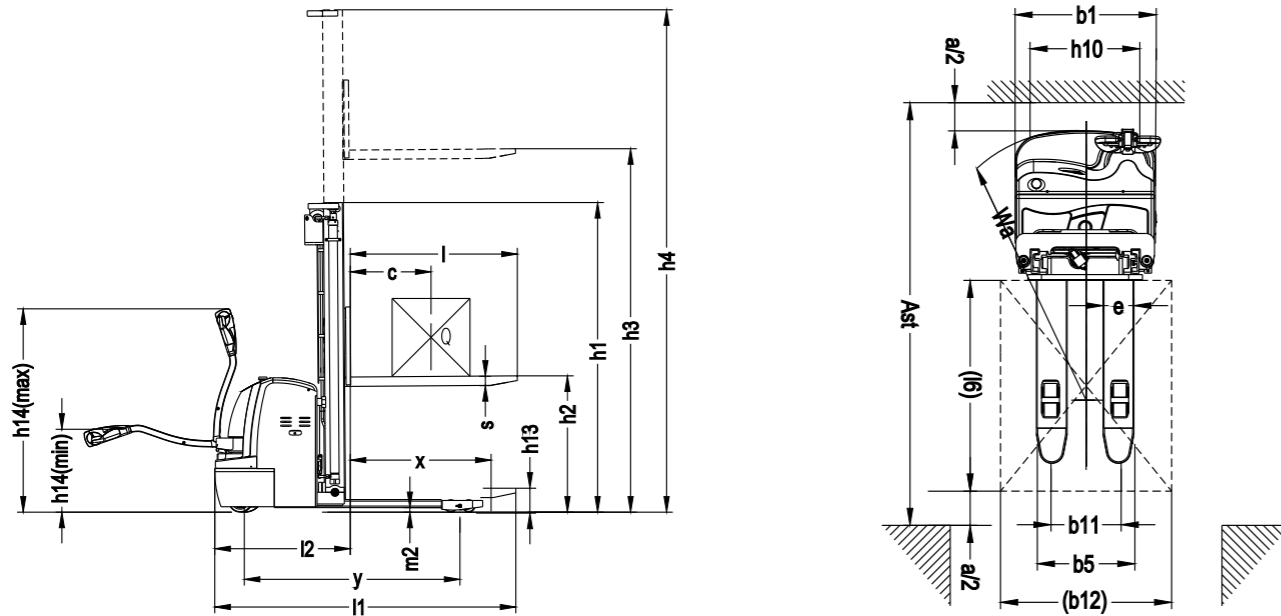

Lifting capacity

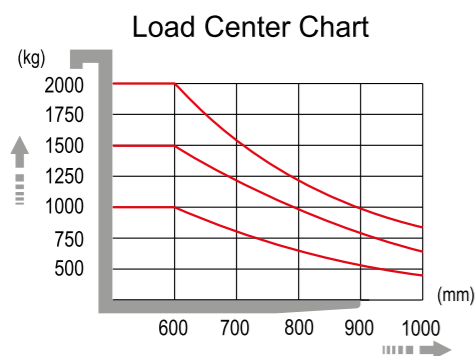
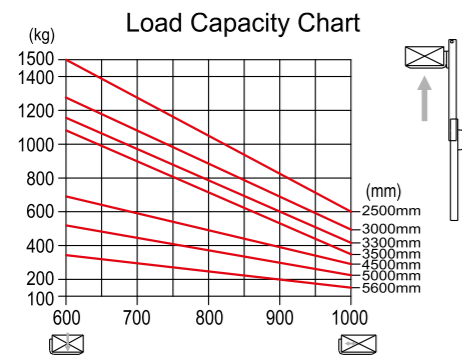

Option

- Integrated Charger
10/12 ES : (24V/15A)
15 ES : (24V/30A)
- Keyless ignition (keypad)
- Battery trolley
- Fork length (mm)
10/12/15 ES : 800; 900; 1000; 1200

10/12ES

- Lifting height 2500 mm, Duplex mast without free lift
- Lifting height 3300 mm, Duplex mast without free lift

15ES

- Tiller head with big control buttons
- Coldstore specification -18°C
- Initial lift
- Lifting height 3000 mm, Duplex mast without free lift
- Lifting height 3500 mm, Duplex mast without free lift
- Lifting height 2500 mm, Duplex mast with free lift
- Lifting height 3500 mm, Duplex mast with free lift
- Lifting height 4500 mm, Triplex mast with free lift
- Lifting height 5000 mm, Triplex mast with free lift
- Lifting height 5600 mm, Triplex mast with free lift

Specification (according to VDI 2198)

Characteristics						
1.1	manufacturer (abbreviation)		Hyundai	Hyundai	Hyundai	
1.2	Model		10ES	12ES	15ES	
1.3	Drive type		electric	electric	electric	
1.4	Operator type		pedestrian	pedestrian	pedestrian	
1.5	Load capacity/rated load	Q	kg	1000	1200	1500
1.6	Load center distance	c	mm	500	500	600
1.8	Load distance	x	mm	697	697	697
1.9	Wheelbase	y	mm	1335	1335	1383
Weight						
2.1	Service weight (with battery)		kg	700 / 730 / 750	710 / 740 / 760	1230 / 1245 / 1260 / 1270
2.2	Axle load, front/rear, loaded		kg	950 / 770	1060 / 870	1470 / 1310
2.3	Axle load, front/rear, unloaded		kg	555 / 165	560 / 170	900 / 380
Wheels/Chassis						
3.1	Tyres: solid rubber, super elastic, pneumatic, polyurethane			polyurethane	polyurethane	polyurethane
3.2	Tyre size, front			φ 250 × 70	φ 250 × 70	φ 250 × 70
3.3	Tyre size, rear			φ 80 × 70	φ 80 × 70	φ 80 × 84
3.4	Additional wheels (dimensions)			φ 150 × 60	φ 150 × 60	φ 150 × 60
3.5	Wheels number, front/rear (x = driven wheels)			1x +1/4	1x +1/4	1x +1/4
3.6	Tread, front	b10	mm	520	520	520
3.7	Tread, rear	b11	mm	410 / 525	410 / 525	404 / 525
Dimension						
4.2	Height of mast, lowered	h1	mm	2087 / 1837 / 2087 / 2237	2087 / 1837 / 2087 / 2237	1805 / 2055 / 2205 / 2305 / 2120 / 2280 / 2480
4.3	Free lift height (optional)			N/A	N/A	1300 / 1550 / 1700 / 1800 / 1570 / 1740 / 1940
4.4	Lift height	h3	mm	1600 / 2500 / 3000 / 3300	1600 / 2500 / 3000 / 3300	2500 / 3000 / 3300 / 3500 / 4500 / 5000 / 5600
4.5	Max. height of mast, extended	h4	mm	2087 / 3087 / 3587 / 3887	2087 / 3087 / 3587 / 3887	3025 / 3525 / 3825 / 4025 / 5100 / 5580 / 6180
4.9	Min. / Max. height of operation handle, in driving position	h14	mm	670 / 1300	670 / 1300	670 / 1300
4.15	Height, lowered	h13	mm	90	90	90
4.19	Overall length	l1	mm	1965	1965	1950
4.20	Length to fork face	l2	mm	792	792	878
4.21	Overall width of truck body	b1	mm	820	820	820
4.22	Fork dimension	s/e/l	mm	60 / 170 / 1070 (1150)	60 / 170 / 1070 (1150)	60 / 180 / 1070 (1150)
4.25	Overall width of fork	b5	mm	570 / 695	570 / 695	570 / 695
4.32	Wheelbase ground distance	m2	mm	28	28	31
4.33	Aisle width, with pallet 1000 x 1200 crosswise	Ast	mm	2400	2400	2450
4.34	Aisle width, with pallet 800 x 1200 lengthwise	Ast	mm	2370	2370	2420
4.35	Turning radius	Wa	mm	1525	1525	1575
Performance Data						
5.1	traveling speed, loaded/unloaded		km/h	5.3 / 5.6	5.3 / 5.6	5.8 / 6
5.2	Lifting speed, loaded/unloaded		m/s	0.06 / 0.13	0.06 / 0.13	0-0.12 / 0-0.19
5.3	Lowering speed, loaded/unloaded		m/s	0.13 / 0.10	0.13 / 0.10	0-0.35 / 0-0.12
5.7	Gradeability, loaded/unloaded		%	6 / 15	6 / 15	8 / 15
5.10	traveling brake			electromagnetic brake	electromagnetic brake	electromagnetic brake
Motor						
6.1	Driving motor power		kW	1.2 (AC)	1.2 (AC)	1.5 (AC)
6.2	Lifting motor power		kW	2.2	2.2	3.2
6.4	Battery voltage/rated capacity		V/Ah	24 / 120	24 / 120	24 / 300
6.5	Battery weight		kg	90	90	300

Electric Stacker

12ESN



Standard Configurations

12ESN

- Lifting Capacity : 1200 kg
- AC Drive Motor : 1.2 kW
- Lift motor : 2.2 kW
- Curtis controller
- Drive wheel : 250 x 70 mm
- Double Polyurethane Load wheel (size: 80 x 70 mm)
- Hourmeter, battery discharge indicator (BDI) & lift cut off
- Simplex mast, Lifting height 1950 mm
- Lowered Height : 2.33 m
- Ergonomic low-mounted tiller
- Overall Fork Width x Length : 570 mm x 1150 mm
- Turtle switch / crawl speed button
- Automatic drive speed reduction (lifting over 1.8 m)
- Integrated charger
- Belly Switch
- Gel battery

Advantages

SAFETY AND PRODUCTIVITY

- AC technology gives high performance and low maintenance (no carbon brushes)
- Intelligent regenerative brake system.
- Multi-functional display with BDI and hour meter etc.
- Proportional travel speed control.
- Switch shuts off liftmotor
- Turtle mode switch, for safe maneuverability with tiller in upright position
- Long tiller ensures large safety distance between operator and truck

STRUCTURE DESIGN

- The closed motor structure is water- and dust resistant
- Offset low mounted tiller for improved visibility

SERVICEABILITY

- Easy access to all components thanks to removal of 1-piece front cover
- Maintenance free gel battery

■ Photo may include optional equipment.

Dimensions

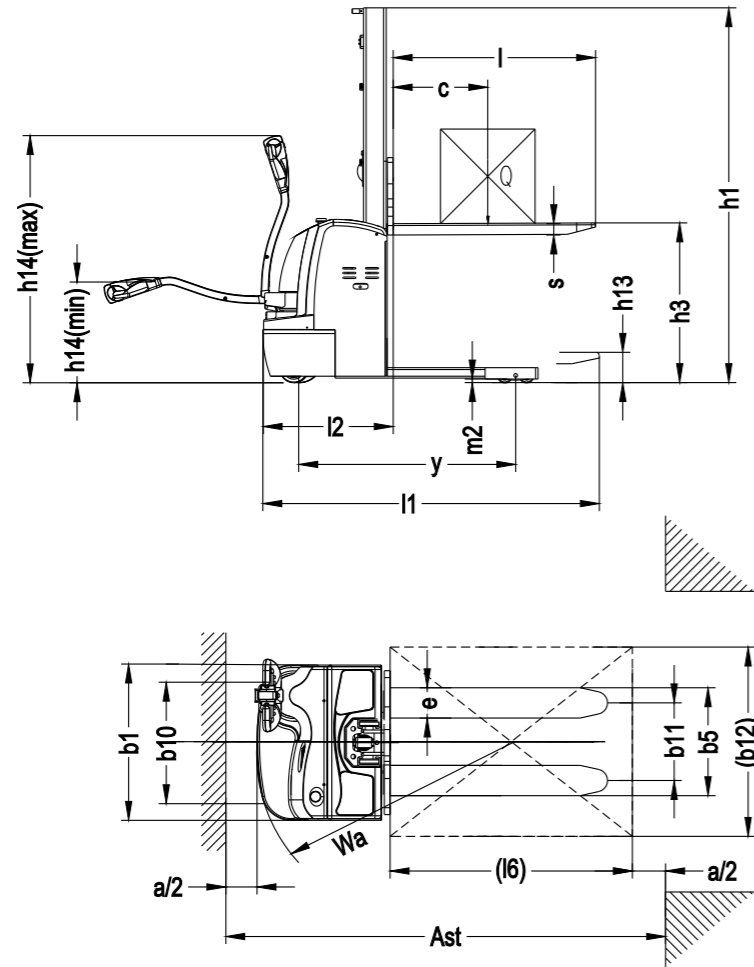

Lifting capacity

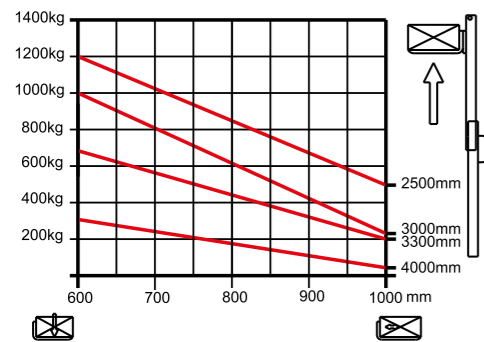

Option

- Lifting height 1600 mm
- Lifting height 2800 mm
- Fork length (mm): 800; 900; 1000; 1200

Specification (according to VDI 2198)

Characteristics			
1.1	manufacturer (abbreviation)		Hyundai
1.2	Model		12ESN
1.3	Drive type		electric
1.4	Operator type		walking
1.5	Load capacity/rated load	Q	kg 1200
1.6	Load center distance	c	mm 500
1.8	Load distance	x	mm 630
1.9	Wheelbase	y	mm 1146
Weight			
2.1	Service weight (with battery)		kg 590
2.2	Axle load, front/rear, loaded		kg 790 / 1000
2.3	Axle load, front/rear, unloaded		kg 195 / 395
Wheels/Chassis			
3.1	Tyres: solid rubber, super elastic, pneumatic, polyurethane		polyurethane
3.2	Tyre size, front		φ 250 × 70
3.3	Tyre size, rear		φ 80 × 70
3.4	Additional wheels (dimensions)		φ 150 × 60
3.5	Wheels number, front/rear (x = driven wheels)		1x +1/4
3.6	Tread, front	b10	mm 520
3.7	Tread, rear	b11	mm 400
Dimension			
4.2	Height of mast, lowered	h1	mm 1980 / 2330
4.4	Lift height	h5	mm 1600 / 1950
4.5	Max. height of mast, extended	h4	mm 1980 / 2330
4.9	Min. / Max. height of operation handle, in driving position	h14	mm 670 / 1300
4.15	Height, lowered	h13	mm 90
4.19	Overall length	l1	mm 1780 / 1860
4.20	Length to fork face	l2	mm 708
4.21	Overall width of truck body	b1	mm 820
4.22	Fork dimension	s/e/l	mm 1070 / 1150
4.25	Overall width of fork	b5	mm 570
4.32	Wheelbase ground distance	m2	mm 30
4.33	Aisle width, with pallet 1000 x 1200 crosswise	Ast	mm 2180
4.34	Aisle width, with pallet 800 x 1200 lengthwise	Ast	mm 2220
4.35	Turning radius	Wa	mm 1338
Performance Data			
5.1	traveling speed, loaded/unloaded	km/h	5.3 / 6.0
5.2	Lifting speed, loaded/unloaded	m/s	0.11 / 0.19
5.3	Lowering speed, loaded/unloaded	m/s	0.16 / 0.11
5.8	Max. gradeability, loaded/unloaded		6 / 15
5.10	traveling brake		electromagnetic brake
Motor			
6.1	Driving motor power	kW	1.2 (AC)
6.2	Lifting motor power	kW	2.2
6.4	Battery voltage/rated capacity	V/Ah	24/80
6.5	Battery weight	kg	50

Electric Stacker

15ESR



Standard Configurations

15ESR

- Lifting Capacity : 1500 kg
- AC Drive Motor : 1.5 kW
- 8.5 km/h
- Lift motor 3.2 kW
- Curtis controller
- Drive wheel : 250 x 70 mm
- Double Polyurethane Load wheel (size: 84 x 80mm)
- Hourmeter, battery discharge indicator (BDI) & Limiter with lift cut off
- Duplex 3.0 m Mast with free lift
- Fork Width x Length : 570 mm x 1150 mm
- Turtle switch / crawl speed button
- German Frei tiller with convenient control buttons
- Proportional Lifting
- Automatic speed reduction (lifting over 1.8 m)
- Belly switch
- Side battery removal
- Stand on platform
- EPS (Electric Power Steering)
- Travel speed reduction

Advantages

SAFETY AND PRODUCTIVITY

- AC technology gives high performance and low maintenance (no carbon brushes)
- Mast lowering damping cushion
- Multi-functional display with BDI and hour meter etc.
- Side battery removal for multiple shift operation
- Auto deceleration function.
- Turtle mode switch, for safe maneuverability with tiller in upright position.
- Proportional travel speed control.
- Effortless steering (EPS), less fatigue
- Suspended platform for comfortable operation
- Intelligent regenerative brake system for fast and efficient handling
- Precision in handling due to proportional hydraulics
- Anti roll-back on gradients (parking brake)
- Lift limit switch shuts off liftmotor at max lifting height

STRUCTURE DESIGN

- The closed motor structure is water- and dust resistant (IP 44)
- Spring-loaded castors improve lateral stability on uneven floors and enhance truck performance and service life.
- Welded type fork.
- Lifting height up to 5600 mm

SERVICEABILITY

- CANbus technology reduces wiring complexity.
- All pivot points have grease fittings and serviceable bushings, to reduce component-wearing.
- Easy access to all components thanks to removal of 1-piece front cover.

■ Photo may include optional equipment.

Dimensions

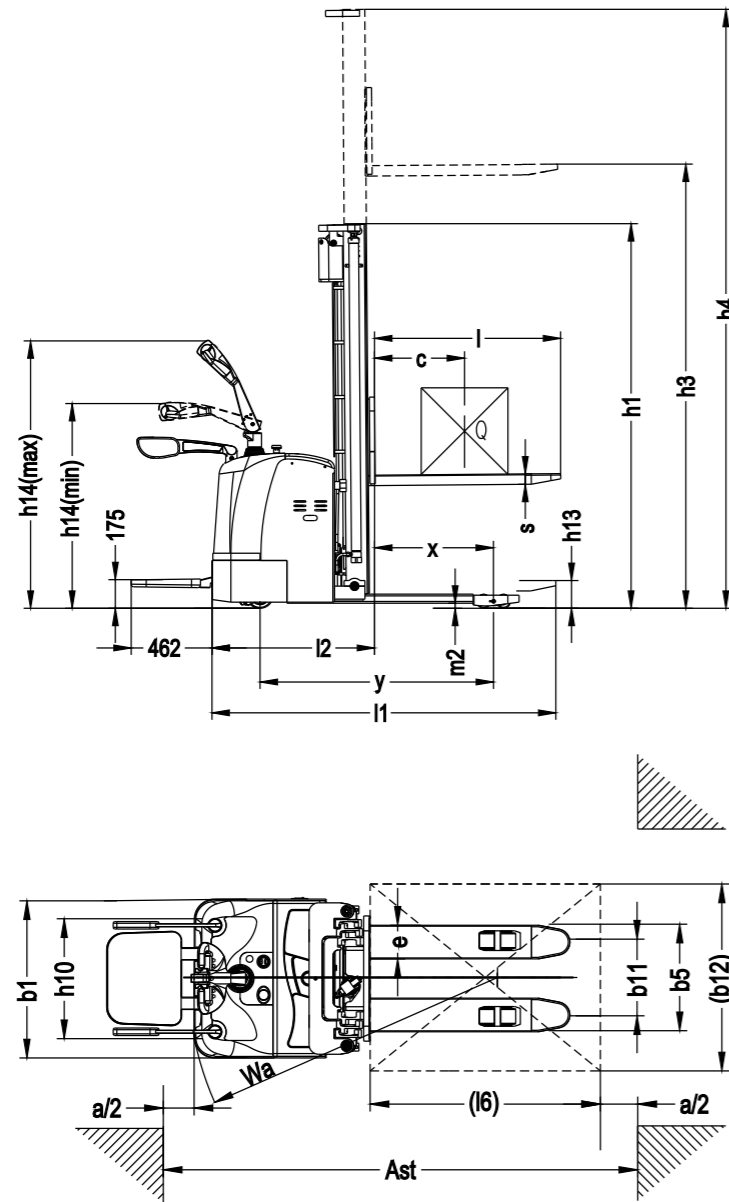

Option

- Traveling speed 6 km/h
- Integrated Charger (24V / 40A)
- Coldstore specification -18°C
- Keyless ignition (keypad)
- Battery trolley
- Initial lift
- Fork length (mm) 800; 900; 1000; 1200

- Lifting height 2500 mm, Duplex mast without free lift
- Lifting height 3000 mm, Duplex mast without free lift
- Lifting height 3300 mm, Duplex mast without free lift
- Lifting height 3500 mm, Duplex mast without free lift
- Lifting height 2500 mm, Duplex mast with free lift
- Lifting height 3500 mm, Duplex mast with free lift
- Lifting height 4500mm, Triplex mast with free lift
- Lifting height 5000mm, Triplex mast with free lift
- Lifting height 5600mm, Triplex mast with free lift

Specification (according to VDI 2198)

Characteristics			
1.1	manufacturer (abbreviation)		Hyundai
1.2	Model		15ESR
1.3	Drive type		electric
1.4	Operator type		pedestrian / standing
1.5	Load capacity/rated load	Q	kg 1500
1.6	Load center distance	c	mm 600
1.8	Load distance	x	mm 672
1.9	Wheelbase	y	mm 1378
Weight			
2.1	Service weight (with battery)		kg 1280
2.2	Axle load, front/rear, loaded		kg 1470/1310
2.3	Axle load, front/rear, unloaded		kg 900/380
Wheels/Chassis			
3.1	Tyres: solid rubber, super elastic, pneumatic, polyurethane		polyurethane
3.2	Tyre size, front		φ 250 × 70
3.3	Tyre size, rear		φ 80 × 84
3.4	Additional wheels (dimensions)		φ 150 × 60
3.5	Wheels number, front/rear (x = driven wheels)		1x +2/4
3.6	Tread, front	b10	mm 580
3.7	Tread, rear	b11	mm 404 / 530
Dimension			
4.2	Height of mast, lowered	h1	mm 1735 / 1985 / 2135 / 2235 / 2050 / 2210 / 2410
4.4	Lift height	h5	mm 1300 / 1550 / 1700 / 1800 / 1570 / 1740 / 1940
4.5	Max. height of mast, extended	h3	mm 2500 / 3000 / 3300 / 3500 / 4500 / 5000 / 5600
4.7	Lifting height for leg	h4	mm 2955 / 3455 / 3755 / 3955 / 5070 / 5550 / 6150
4.9	Min. / Max. height of operation handle, in driving position	h14	mm 1150 / 1450
4.15	Height, lowered	h13	mm 90
4.19	Overall length	l1	mm 2020 / 2100
4.20	Length to fork face	l2	mm 950
4.21	Overall width of truck body	b1	mm 850
4.22	Fork dimension	s/e/l	mm 60 / 180 / 1070 (1150)
4.25	Overall width of fork	b5	mm 570 / 695
4.32	Wheelbase ground distance	m2	mm 31
4.33	Aisle width, with pallet 1000 x 1200 crosswise	Ast	mm 2535
4.34	Aisle width, with pallet 800 x 1200 lengthwise	Ast	mm 2515
4.35	Turning radius	Wa	mm 1655
Performance Data			
5.1	traveling speed, loaded/unloaded	km/h	6.0 / 8.5
5.2	Lifting speed, loaded/unloaded	m/s	0-0.15 / 0-0.28
5.3	Lowering speed, loaded/unloaded	m/s	0-0.41 / 0-0.27
5.8	Max. gradeability, loaded/unloaded		8 / 15
5.10	traveling brake		electromagnetic brake
Motor			
6.1	Driving motor power	kW	1.5 (AC)
6.2	Lifting motor power	kW	3.2
6.4	Battery voltage/rated capacity	V/Ah	24 / 300
6.5	Battery weight	kg	300

Manual Hand Pallet Truck

25HP/25HPW

Standard Configurations

25HP

- Lifting Capacity : 2500 kg
- Polyurethane drive steering wheel
- Double Polyurethane load wheels
- Overall Fork Width x Length : 550 mm x 1150 mm
- 210° steering arc

25HPW

- Lifting Capacity : 2500 kg
- Double Polyurethane load wheels
- Overall Fork Width x Length : 550 mm x 1150 mm
- 210° steering arc
- Weighing Scale

Option

- Nylon drive wheel and double nylon load wheels
- Rubber drive wheel and double Polyurethane load wheels
- Polyurethane drive wheel and single Polyurethane load wheels
- Nylon drive wheel and single nylon load wheels
- Fully rubber wrapped handgrip
- Quick lift (5 strokes to reach max.height)
- Fork length (mm): 800; 900; 1000; 1100; 1220
- Overall fork Width x Length: 685 x 1150 mm
- Foot pedal release
- Foot pedal release extra long

Dimension & Specification (according to VDI 2198)

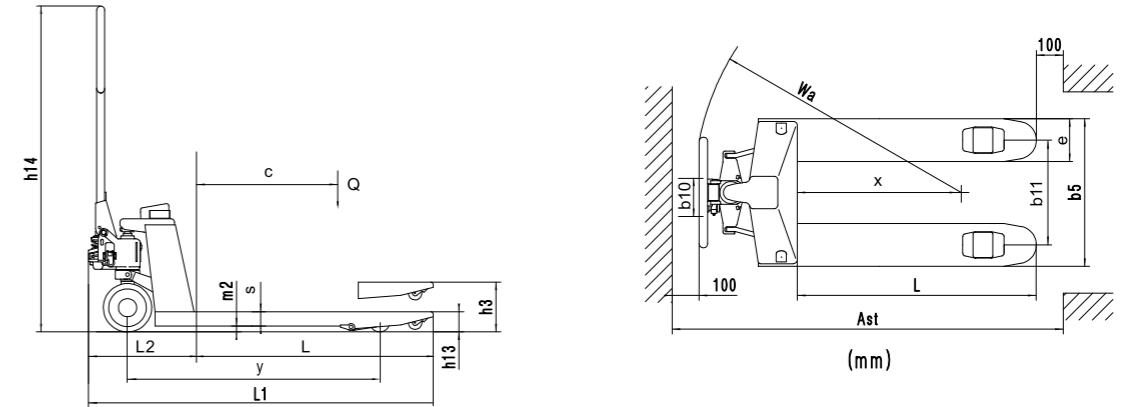

Characteristics			
1.1	Manufacturer (abbreviation)		Hyundai
1.2	Model		25HP
1.3	Drive type		manual
1.4	Operator type		hand
1.5	Load capacity/rated load	kg	2500
1.6	Load center distance	c mm	32/22
1.8	Load distance	x mm	600
1.9	Wheelbase	y mm	1153 / 1223
Weight			
2.1	Service weight	kg	58-70
Wheels/Chassis			
3.1	Tyres: solid rubber, super elastic, pneumatic, polyurethane		polyurethane
3.2	Tyre size, front (Steering wheel)	mm	Φ 200 / Φ 180
3.3	Tyre size, rear (Fork wheel single)	mm	Φ 80 x 93 / Φ 74 x 93
	Tyre size, rear (Fork wheel tandem)	mm	Φ 80 x 70 / Φ 74 x 70
3.5	Wheels number, front/rear (x = driven wheels)		2x+2/4
3.6	Tread, front	b10 mm	111
3.7	Tread, rear	b11 mm	360 / 390 / 525
Dimension			
4.4	Max. Lift height	h3 mm	195 / 185
4.9	Min. / Max. height of operation handle, in driving position	h14 mm	1214
4.15	Height, lowered	h13 mm	85/75
4.19	Overall length	l1 mm	1543/1613
4.20	Length to fork face	l2 mm	393.5
4.22	Fork dimension	s/e/l mm	53 / 160 / (1150 / 1220)
4.25	Overall width of fork	b5 mm	520 / 550 / 685
4.32	Wheelbase ground distance	m2 mm	32 / 22
4.33	Aisle width, with pallet 1000 x 1200 crosswise	Ast mm	1743 / 1813
4.34	Aisle width, with pallet 800 x 1200 lengthwise	Ast mm	1783 / 1813
4.35	Turning radius	Wa mm	1276 / 1346

■ Photo may include optional equipment.

- * Standard and optional equipment may vary per country. Contact your Hyundai dealer for more information.
- * The photos may include attachments and optional equipment that are not available in your area.
- * Materials and specifications are subject to change without advance notice.
- * All imperial measurements rounded off to the nearest pound or inch.



Conforms to EN ISO3691-1:2012
EN1175-1:1998/A1:2010
EN16307-1:2013

 **HYUNDAI MATERIAL HANDLING**

PLEASE CONTACT

Hyundai Construction Equipment Europe nv

Hyundailaan 4, 3980 Tessenderlo, Belgium **Tel:** (32) 14-56-2200 **Fax:** (32) 14-59-3405

www.hyundai.eu

EN - 2019.05 Rev 2